

BILL OF MATERIALS					
POSN	ITEM ID	NAME	DESCRIPTION	QTY	UM
1	SKU0139861	QF40-150-ARV	EUDF-SUPP CENTERING RING,ALUM,QF40,FKM	2	EA
2	SKU0140021	QF40XQF16C	EUDF-SUPP REDUCING FULL NIPPLE,CONICAL, SS,QF40 TO QF16	1	EA
3	SKU0139863	QF40-150-BC	EUDF-SUPP CLAMP,BULKHEAD,AL,QF40,INCS (6)10-32X5/8" SS SCREWS	2	EA
4	SKU0192428	HCHM0508-016S4	SCREW, SOCKET HEAD CAP,SS, M5 X 16MM LG	12	EA
5	SKU0139410	QF16-075-ARV	EUDF-SUPP CENTERING RING,ALUM,QF16,BROWN FKM O-RING	1	EA
6	SKU0139539	QF16-075-ARV	EUDF-SUPP ADAPTER,SS,QF16 TO 1/4"MALE VCR	1	EA
7	SKU0139416	QF16-075-C	EUDF-SUPP CLAMP,ALUMINIUM,QF16,CAST 1/2" & 3/4"	1	EA
8	SKU0102292	4XVCR-GAC	EUDF-SUPP GASKET,VCR,CAJON,COPPER,1/4"	13	EA
9	SKU0260997	FPR-ND-71-6.35-2	EUDF-SUPP VALVE, DIAPHRAGM, SS, NC ACTUATOR, 1/2" FEMALE UJR FACE SEAL	2	EA
10	SKU0270737	KQ2L04-M5	ELBOW,ONE TOUCH,4MM TUBE,M5 X0.8 THREAD	2	EA
11	SKU0123284	F0275XQF40	EUDF-SUPP ADAPTER,SS,2-3/4"UHV FLANGE TO QF40 FLANGE	1	EA
12	SKU0130410	L-0275	EUDF-SUPP ELBOW, RADIUS, 2.46"A, 1.5"OD, 2.75" FLANGE, UHV FITTING	1	EA
13	SKU0275546	390-222	EUDF CAP MANOMETER, 1 TORR, .25% READING ACCURACY, DN40CF-R, 15 PIN	1	EA
14	SKU0350491	FKIT0275MPLATENUTSIL	F0275 HARDWARE KIT, M6X35, HEX HEAD	2	EA
15	SKU0138363	PN-0275M	PLATE NUT SET, FOR 2-3/4"OD UHV FLGS,24/SET,METRIC M6	1	EA
17	SKU0265245	FC-F100N2-233	MASS FLOW CONTROLLER, 100S, N2, ELASTOMER SEAL, 100 SCCM, 1/4" MALE UJR,	1	EA
18	SKU0153247	WPNM040S4	WASHERS,FLAT,M4,SS	2	EA
19	SKU0182165	HBHM0407-006S4	SCREW,BUTTON HEADCAP,18-8SS,M4 X 6MM, .7 PITCH	2	EA
20	SKU0272037	D-A0050915	EUDF-SUPP GAS INLET ASSEMBLY	1	EA
21	SKU0279423	D-A0052657	EUDF-SUPP MODULAR PLATFORM,GAS, 5 MFC MANIFOLD WELDMENT	1	EA
22	SKU0102231	4FVCR-CP	CAP,FEMALE,VCR,CAJON,SS,1/4"	4	EA
23	SKU0103410	6LV-4WVCR9DF	EUDF-SUPP ELBOW,UNION,SWAGelok,3.16SS,1/4 WELDED,FVCR	1	EA
24	SKU0354674	PTN112684-02S002	GAS LINE, PC GAS INJECTION TO SPLIT	1	EA
25	SKU0354675	PTN112684-02S001	GAS LINE, MANIFOLD ELBOW TO SPLIT	1	EA

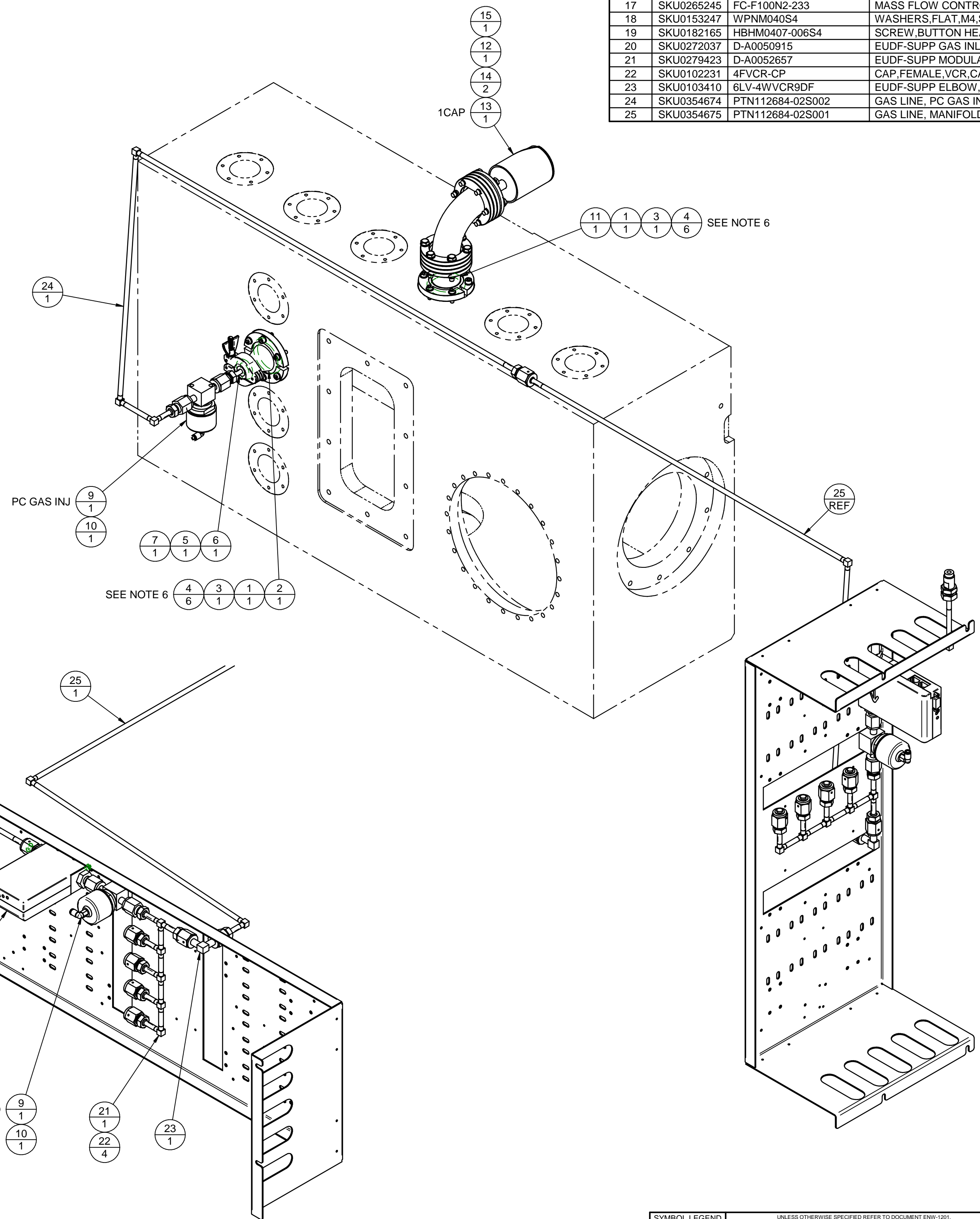
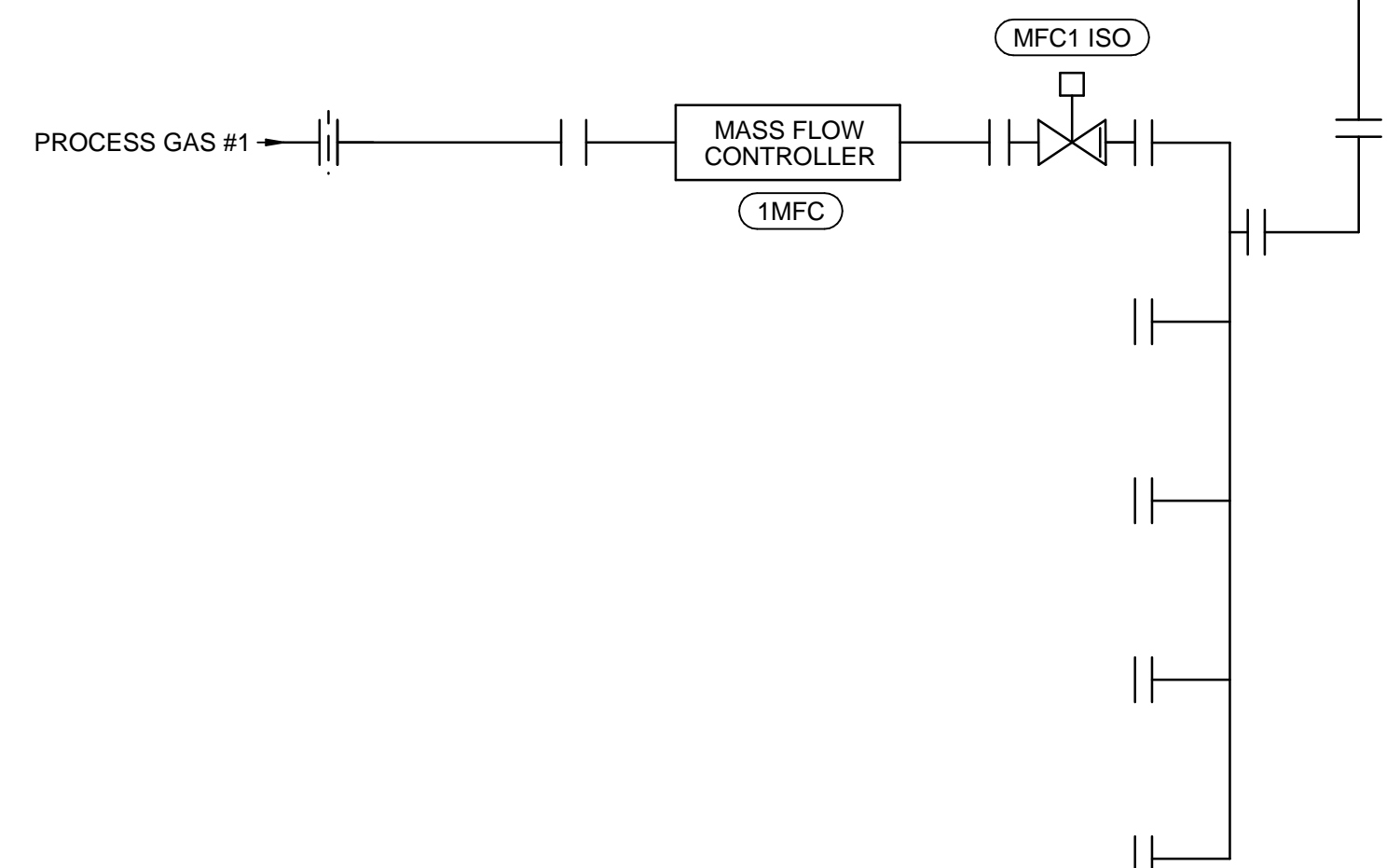
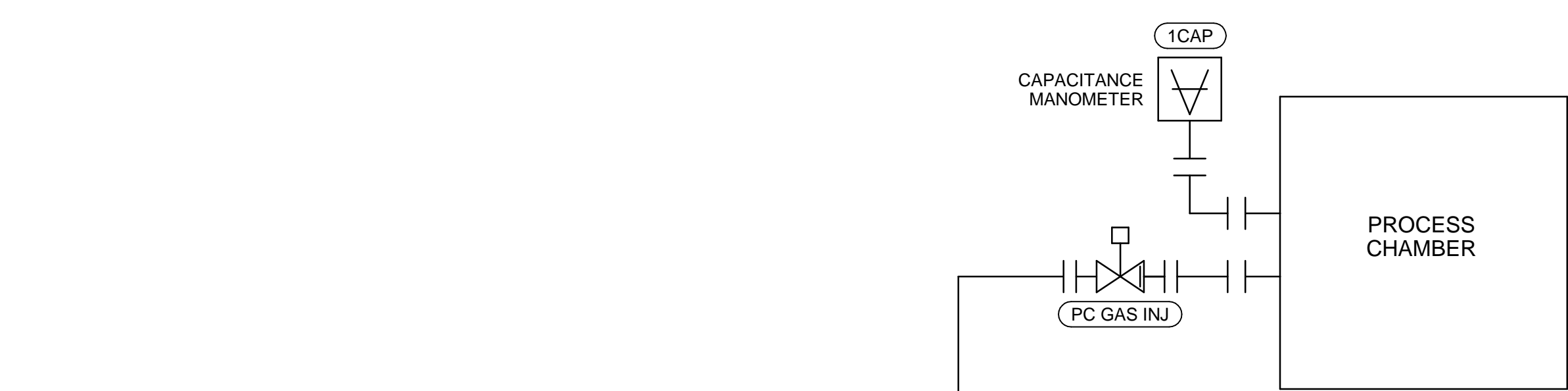

- NOTES:
1. ALL DIMENSIONS ARE IN INCHES (MILLIMETERS), REFER TO TABLE 1 FOR STANDARD TOLERANCING INFORMATION.
 2. CLEANING PROCEDURE: MSW-DCP-100, LEVEL II
 3. DRAWING BASED ON: SKU0326712
 4. DO NOT INSTALL INLET BULKHEAD UNTIL AFTER PANEL INSTALLATION.
 5. USE AT EVERY VCR CONNECTION.
 6. REPLACE #10-32 SCREWS.

SYMBOL	REVISION	DESCRIPTION
△ <td>1</td> <td>UNLESS OTHERWISE SPECIFIED REFER TO DOCUMENT ENW-1201, KJLC 2D FINISHED DIMENSIONS AND MANUFACTURING PRACTICES</td>	1	UNLESS OTHERWISE SPECIFIED REFER TO DOCUMENT ENW-1201, KJLC 2D FINISHED DIMENSIONS AND MANUFACTURING PRACTICES
⊕ <td>1</td> <td>MACHINED TOLERANCES (UNLESS OTHERWISE NOTED)</td>	1	MACHINED TOLERANCES (UNLESS OTHERWISE NOTED)
⊕ <td>1</td> <td>FABRICATION/WELDMENT TOLERANCES (UNLESS OTHERWISE NOTED)</td>	1	FABRICATION/WELDMENT TOLERANCES (UNLESS OTHERWISE NOTED)
⊕ <td>1</td> <td>OPERATING PRESSURES (UNLESS OTHERWISE NOTED)</td>	1	OPERATING PRESSURES (UNLESS OTHERWISE NOTED)
⊕ <td>1</td> <td>OPERATING TEMPERATURES (UNLESS OTHERWISE NOTED)</td>	1	OPERATING TEMPERATURES (UNLESS OTHERWISE NOTED)
⊕ <td>1</td> <td>OPERATING VOLTAGES (UNLESS OTHERWISE NOTED)</td>	1	OPERATING VOLTAGES (UNLESS OTHERWISE NOTED)
⊕ <td>1</td> <td>OPERATING CURRENTS (UNLESS OTHERWISE NOTED)</td>	1	OPERATING CURRENTS (UNLESS OTHERWISE NOTED)
⊕ <td>1</td> <td>OPERATING FLOW RATES (UNLESS OTHERWISE NOTED)</td>	1	OPERATING FLOW RATES (UNLESS OTHERWISE NOTED)
⊕ <td>1</td> <td>OPERATING SPEEDS (UNLESS OTHERWISE NOTED)</td>	1	OPERATING SPEEDS (UNLESS OTHERWISE NOTED)
⊕ <td>1</td> <td>OPERATING TORQUES (UNLESS OTHERWISE NOTED)</td>	1	OPERATING TORQUES (UNLESS OTHERWISE NOTED)
⊕ <td>1</td> <td>OPERATING WEIGHTS (UNLESS OTHERWISE NOTED)</td>	1	OPERATING WEIGHTS (UNLESS OTHERWISE NOTED)
⊕ <td>1</td> <td>OPERATING TIMES (UNLESS OTHERWISE NOTED)</td>	1	OPERATING TIMES (UNLESS OTHERWISE NOTED)
⊕ <td>1</td> <td>OPERATING DISTANCES (UNLESS OTHERWISE NOTED)</td>	1	OPERATING DISTANCES (UNLESS OTHERWISE NOTED)
⊕ <td>1</td> <td>OPERATING ANGLES (UNLESS OTHERWISE NOTED)</td>	1	OPERATING ANGLES (UNLESS OTHERWISE NOTED)
⊕ <td>1</td> <td>OPERATING PHASES (UNLESS OTHERWISE NOTED)</td>	1	OPERATING PHASES (UNLESS OTHERWISE NOTED)
⊕ <td>1</td> <td>OPERATING FREQUENCIES (UNLESS OTHERWISE NOTED)</td>	1	OPERATING FREQUENCIES (UNLESS OTHERWISE NOTED)
⊕ <td>1</td> <td>OPERATING VIBRATIONS (UNLESS OTHERWISE NOTED)</td>	1	OPERATING VIBRATIONS (UNLESS OTHERWISE NOTED)
⊕ <td>1</td> <td>OPERATING ACCELERATIONS (UNLESS OTHERWISE NOTED)</td>	1	OPERATING ACCELERATIONS (UNLESS OTHERWISE NOTED)
⊕ <td>1</td> <td>OPERATING SHOCKS (UNLESS OTHERWISE NOTED)</td>	1	OPERATING SHOCKS (UNLESS OTHERWISE NOTED)
⊕ <td>1</td> <td>OPERATING RESONANCES (UNLESS OTHERWISE NOTED)</td>	1	OPERATING RESONANCES (UNLESS OTHERWISE NOTED)
⊕ <td>1</td> <td>OPERATING MODES (UNLESS OTHERWISE NOTED)</td>	1	OPERATING MODES (UNLESS OTHERWISE NOTED)
⊕ <td>1</td> <td>OPERATING STATES (UNLESS OTHERWISE NOTED)</td>	1	OPERATING STATES (UNLESS OTHERWISE NOTED)
⊕ <td>1</td> <td>OPERATING TRANSITIONS (UNLESS OTHERWISE NOTED)</td>	1	OPERATING TRANSITIONS (UNLESS OTHERWISE NOTED)
⊕ <td>1</td> <td>OPERATING SEQUENCES (UNLESS OTHERWISE NOTED)</td>	1	OPERATING SEQUENCES (UNLESS OTHERWISE NOTED)
⊕ <td>1</td> <td>OPERATING PROCEDURES (UNLESS OTHERWISE NOTED)</td>	1	OPERATING PROCEDURES (UNLESS OTHERWISE NOTED)
⊕ <td>1</td> <td>OPERATING METHODS (UNLESS OTHERWISE NOTED)</td>	1	OPERATING METHODS (UNLESS OTHERWISE NOTED)
⊕ <td>1</td> <td>OPERATING TOOLS (UNLESS OTHERWISE NOTED)</td>	1	OPERATING TOOLS (UNLESS OTHERWISE NOTED)
⊕ <td>1</td> <td>OPERATING EQUIPMENT (UNLESS OTHERWISE NOTED)</td>	1	OPERATING EQUIPMENT (UNLESS OTHERWISE NOTED)
⊕ <td>1</td> <td>OPERATING MATERIALS (UNLESS OTHERWISE NOTED)</td>	1	OPERATING MATERIALS (UNLESS OTHERWISE NOTED)
⊕ <td>1</td> <td>OPERATING SUPPLIES (UNLESS OTHERWISE NOTED)</td>	1	OPERATING SUPPLIES (UNLESS OTHERWISE NOTED)
⊕ <td>1</td> <td>OPERATING SERVICES (UNLESS OTHERWISE NOTED)</td>	1	OPERATING SERVICES (UNLESS OTHERWISE NOTED)
⊕ <td>1</td> <td>OPERATING PERSONNEL (UNLESS OTHERWISE NOTED)</td>	1	OPERATING PERSONNEL (UNLESS OTHERWISE NOTED)
⊕ <td>1</td> <td>OPERATING SAFETY (UNLESS OTHERWISE NOTED)</td>	1	OPERATING SAFETY (UNLESS OTHERWISE NOTED)
⊕ <td>1</td> <td>OPERATING COMPLIANCE (UNLESS OTHERWISE NOTED)</td>	1	OPERATING COMPLIANCE (UNLESS OTHERWISE NOTED)
⊕ <td>1</td> <td>OPERATING STANDARDS (UNLESS OTHERWISE NOTED)</td>	1	OPERATING STANDARDS (UNLESS OTHERWISE NOTED)
⊕ <td>1</td> <td>OPERATING REGULATIONS (UNLESS OTHERWISE NOTED)</td>	1	OPERATING REGULATIONS (UNLESS OTHERWISE NOTED)
⊕ <td>1</td> <td>OPERATING CODES (UNLESS OTHERWISE NOTED)</td>	1	OPERATING CODES (UNLESS OTHERWISE NOTED)
⊕ <td>1</td> <td>OPERATING REFERENCES (UNLESS OTHERWISE NOTED)</td>	1	OPERATING REFERENCES (UNLESS OTHERWISE NOTED)
⊕ <td>1</td> <td>OPERATING SOURCES (UNLESS OTHERWISE NOTED)</td>	1	OPERATING SOURCES (UNLESS OTHERWISE NOTED)
⊕ <td>1</td> <td>OPERATING DISTRIBUTORS (UNLESS OTHERWISE NOTED)</td>	1	OPERATING DISTRIBUTORS (UNLESS OTHERWISE NOTED)
⊕ <td>1</td> <td>OPERATING VENDORS (UNLESS OTHERWISE NOTED)</td>	1	OPERATING VENDORS (UNLESS OTHERWISE NOTED)
⊕ <td>1</td> <td>OPERATING CONTRACTORS (UNLESS OTHERWISE NOTED)</td>	1	OPERATING CONTRACTORS (UNLESS OTHERWISE NOTED)
⊕ <td>1</td> <td>OPERATING SUBCONTRACTORS (UNLESS OTHERWISE NOTED)</td>	1	OPERATING SUBCONTRACTORS (UNLESS OTHERWISE NOTED)
⊕ <td>1</td> <td>OPERATING PARTNERS (UNLESS OTHERWISE NOTED)</td>	1	OPERATING PARTNERS (UNLESS OTHERWISE NOTED)
⊕ <td>1</td> <td>OPERATING SUPPLIERS (UNLESS OTHERWISE NOTED)</td>	1	OPERATING SUPPLIERS (UNLESS OTHERWISE NOTED)
⊕ <td>1</td> <td>OPERATING MANUFACTURERS (UNLESS OTHERWISE NOTED)</td>	1	OPERATING MANUFACTURERS (UNLESS OTHERWISE NOTED)
⊕ <td>1</td> <td>OPERATING ASSEMBLERS (UNLESS OTHERWISE NOTED)</td>	1	OPERATING ASSEMBLERS (UNLESS OTHERWISE NOTED)
⊕ <td>1</td> <td>OPERATING TESTERS (UNLESS OTHERWISE NOTED)</td>	1	OPERATING TESTERS (UNLESS OTHERWISE NOTED)
⊕ <td>1</td> <td>OPERATING INSPECTORS (UNLESS OTHERWISE NOTED)</td>	1	OPERATING INSPECTORS (UNLESS OTHERWISE NOTED)
⊕ <td>1</td> <td>OPERATING QUALITY CONTROL (UNLESS OTHERWISE NOTED)</td>	1	OPERATING QUALITY CONTROL (UNLESS OTHERWISE NOTED)
⊕ <td>1</td> <td>OPERATING MAINTENANCE (UNLESS OTHERWISE NOTED)</td>	1	OPERATING MAINTENANCE (UNLESS OTHERWISE NOTED)
⊕ <td>1</td> <td>OPERATING REPAIRS (UNLESS OTHERWISE NOTED)</td>	1	OPERATING REPAIRS (UNLESS OTHERWISE NOTED)
⊕ <td>1</td> <td>OPERATING UPGRADES (UNLESS OTHERWISE NOTED)</td>	1	OPERATING UPGRADES (UNLESS OTHERWISE NOTED)
⊕ <td>1</td> <td>OPERATING MODIFICATIONS (UNLESS OTHERWISE NOTED)</td>	1	OPERATING MODIFICATIONS (UNLESS OTHERWISE NOTED)
⊕ <td>1</td> <td>OPERATING IMPROVEMENTS (UNLESS OTHERWISE NOTED)</td>	1	OPERATING IMPROVEMENTS (UNLESS OTHERWISE NOTED)
⊕ <td>1</td> <td>OPERATING INNOVATIONS (UNLESS OTHERWISE NOTED)</td>	1	OPERATING INNOVATIONS (UNLESS OTHERWISE NOTED)
⊕ <td>1</td> <td>OPERATING RESEARCH (UNLESS OTHERWISE NOTED)</td>	1	OPERATING RESEARCH (UNLESS OTHERWISE NOTED)
⊕ <td>1</td> <td>OPERATING DEVELOPMENT (UNLESS OTHERWISE NOTED)</td>	1	OPERATING DEVELOPMENT (UNLESS OTHERWISE NOTED)
⊕ <td>1</td> <td>OPERATING DESIGN (UNLESS OTHERWISE NOTED)</td>	1	OPERATING DESIGN (UNLESS OTHERWISE NOTED)
⊕ <td>1</td> <td>OPERATING CONSTRUCTION (UNLESS OTHERWISE NOTED)</td>	1	OPERATING CONSTRUCTION (UNLESS OTHERWISE NOTED)
⊕ <td>1</td> <td>OPERATING INSTALLATION (UNLESS OTHERWISE NOTED)</td>	1	OPERATING INSTALLATION (UNLESS OTHERWISE NOTED)
⊕ <td>1</td> <td>OPERATING OPERATION (UNLESS OTHERWISE NOTED)</td>	1	OPERATING OPERATION (UNLESS OTHERWISE NOTED)
⊕ <td>1</td> <td>OPERATING MAINTENANCE (UNLESS OTHERWISE NOTED)</td>	1	OPERATING MAINTENANCE (UNLESS OTHERWISE NOTED)
⊕ <td>1</td> <td>OPERATING REPAIRS (UNLESS OTHERWISE NOTED)</td>	1	OPERATING REPAIRS (UNLESS OTHERWISE NOTED)
⊕ <td>1</td> <td>OPERATING UPGRADES (UNLESS OTHERWISE NOTED)</td>	1	OPERATING UPGRADES (UNLESS OTHERWISE NOTED)
⊕ <td>1</td> <td>OPERATING MODIFICATIONS (UNLESS OTHERWISE NOTED)</td>	1	OPERATING MODIFICATIONS (UNLESS OTHERWISE NOTED)
⊕ <td>1</td> <td>OPERATING IMPROVEMENTS (UNLESS OTHERWISE NOTED)</td>	1	OPERATING IMPROVEMENTS (UNLESS OTHERWISE NOTED)
⊕ <td>1</td> <td>OPERATING INNOVATIONS (UNLESS OTHERWISE NOTED)</td>	1	OPERATING INNOVATIONS (UNLESS OTHERWISE NOTED)
⊕ <td>1</td> <td>OPERATING RESEARCH (UNLESS OTHERWISE NOTED)</td>	1	OPERATING RESEARCH (UNLESS OTHERWISE NOTED)
⊕ <td>1</td> <td>OPERATING DEVELOPMENT (UNLESS OTHERWISE NOTED)</td>	1	OPERATING DEVELOPMENT (UNLESS OTHERWISE NOTED)
⊕ <td>1</td> <td>OPERATING DESIGN (UNLESS OTHERWISE NOTED)</td>	1	OPERATING DESIGN (UNLESS OTHERWISE NOTED)
⊕ <td>1</td> <td>OPERATING CONSTRUCTION (UNLESS OTHERWISE NOTED)</td>	1	OPERATING CONSTRUCTION (UNLESS OTHERWISE NOTED)
⊕ <td>1</td> <td>OPERATING INSTALLATION (UNLESS OTHERWISE NOTED)</td>	1	OPERATING INSTALLATION (UNLESS OTHERWISE NOTED)
⊕ <td>1</td> <td>OPERATING OPERATION (UNLESS OTHERWISE NOTED)</td>	1	OPERATING OPERATION (UNLESS OTHERWISE NOTED)
⊕ <td>1</td> <td>OPERATING MAINTENANCE (UNLESS OTHERWISE NOTED)</td>	1	OPERATING MAINTENANCE (UNLESS OTHERWISE NOTED)
⊕ <td>1</td> <td>OPERATING REPAIRS (UNLESS OTHERWISE NOTED)</td>	1	OPERATING REPAIRS (UNLESS OTHERWISE NOTED)
⊕ <td>1</td> <td>OPERATING UPGRADES (UNLESS OTHERWISE NOTED)</td>	1	OPERATING UPGRADES (UNLESS OTHERWISE NOTED)
⊕ <td>1</td> <td>OPERATING MODIFICATIONS (UNLESS OTHERWISE NOTED)</td>	1	OPERATING MODIFICATIONS (UNLESS OTHERWISE NOTED)
⊕ <td>1</td> <td>OPERATING IMPROVEMENTS (UNLESS OTHERWISE NOTED)</td>	1	OPERATING IMPROVEMENTS (UNLESS OTHERWISE NOTED)
⊕ <td>1</td> <td>OPERATING INNOVATIONS (UNLESS OTHERWISE NOTED)</td>	1	OPERATING INNOVATIONS (UNLESS OTHERWISE NOTED)
⊕ <td>1</td> <td>OPERATING RESEARCH (UNLESS OTHERWISE NOTED)</td>	1	OPERATING RESEARCH (UNLESS OTHERWISE NOTED)
⊕ <td>1</td> <td>OPERATING DEVELOPMENT (UNLESS OTHERWISE NOTED)</td>	1	OPERATING DEVELOPMENT (UNLESS OTHERWISE NOTED)
⊕ <td>1</td> <td>OPERATING DESIGN (UNLESS OTHERWISE NOTED)</td>	1	OPERATING DESIGN (UNLESS OTHERWISE NOTED)
⊕ <td>1</td> <td>OPERATING CONSTRUCTION (UNLESS OTHERWISE NOTED)</td>	1	OPERATING CONSTRUCTION (UNLESS OTHERWISE NOTED)
⊕ <td>1</td> <td>OPERATING INSTALLATION (UNLESS OTHERWISE NOTED)</td>	1	OPERATING INSTALLATION (UNLESS OTHERWISE NOTED)
⊕ <td>1</td> <td>OPERATING OPERATION (UNLESS OTHERWISE NOTED)</td>	1	OPERATING OPERATION (UNLESS OTHERWISE NOTED)
⊕ <td>1</td> <td>OPERATING MAINTENANCE (UNLESS OTHERWISE NOTED)</td>	1	OPERATING MAINTENANCE (UNLESS OTHERWISE NOTED)
⊕ <td>1</td> <td>OPERATING REPAIRS (UNLESS OTHERWISE NOTED)</td>	1	OPERATING REPAIRS (UNLESS OTHERWISE NOTED)
⊕ <td>1</td> <td>OPERATING UPGRADES (UNLESS OTHERWISE NOTED)</td>	1	OPERATING UPGRADES (UNLESS OTHERWISE NOTED)
⊕ <td>1</td> <td>OPERATING MODIFICATIONS (UNLESS OTHERWISE NOTED)</td>	1	OPERATING MODIFICATIONS (UNLESS OTHERWISE NOTED)
⊕ <td>1</td> <td>OPERATING IMPROVEMENTS (UNLESS OTHERWISE NOTED)</td>	1	OPERATING IMPROVEMENTS (UNLESS OTHERWISE NOTED)
⊕ <td>1</td> <td>OPERATING INNOVATIONS (UNLESS OTHERWISE NOTED)</td>	1	OPERATING INNOVATIONS (UNLESS OTHERWISE NOTED)
⊕ <td>1</td> <td>OPERATING RESEARCH (UNLESS OTHERWISE NOTED)</td>	1	OPERATING RESEARCH (UNLESS OTHERWISE NOTED)
⊕ <td>1</td> <td>OPERATING DEVELOPMENT (UNLESS OTHERWISE NOTED)</td>	1	OPERATING DEVELOPMENT (UNLESS OTHERWISE NOTED)
⊕ <td>1</td> <td>OPERATING DESIGN (UNLESS OTHERWISE NOTED)</td>	1	OPERATING DESIGN (UNLESS OTHERWISE NOTED)
⊕ <td>1</td> <td>OPERATING CONSTRUCTION (UNLESS OTHERWISE NOTED)</td>	1	OPERATING CONSTRUCTION (UNLESS OTHERWISE NOTED)
⊕ <td>1</td> <td>OPERATING INSTALLATION (UNLESS OTHERWISE NOTED)</td>	1	OPERATING INSTALLATION (UNLESS OTHERWISE NOTED)
⊕ <td>1</td> <td>OPERATING OPERATION (UNLESS OTHERWISE NOTED)</td>	1	OPERATING OPERATION (UNLESS OTHERWISE NOTED)
⊕ <td>1</td> <td>OPERATING MAINTENANCE (UNLESS OTHERWISE NOTED)</td>	1	OPERATING MAINTENANCE (UNLESS OTHERWISE NOTED)
⊕ <td>1</td> <td>OPERATING REPAIRS (UNLESS OTHERWISE NOTED)</td>	1	OPERATING REPAIRS (UNLESS OTHERWISE NOTED)
⊕ <td>1</td> <td>OPERATING UPGRADES (UNLESS OTHERWISE NOTED)</td>	1	OPERATING UPGRADES (UNLESS OTHERWISE NOTED)
⊕ <td>1</td> <td>OPERATING MODIFICATIONS (UNLESS OTHERWISE NOTED)</td>	1	OPERATING MODIFICATIONS (UNLESS OTHERWISE NOTED)
⊕ <td>1</td> <td>OPERATING IMPROVEMENTS (UNLESS OTHERWISE NOTED)</td>	1	OPERATING IMPROVEMENTS (UNLESS OTHERWISE NOTED)
⊕ <td>1</td> <td>OPERATING INNOVATIONS (UNLESS OTHERWISE NOTED)</td>	1	OPERATING INNOVATIONS (UNLESS OTHERWISE NOTED)
⊕ <td>1</td> <td>OPERATING RESEARCH (UNLESS OTHERWISE NOTED)</td>	1	OPERATING RESEARCH (UNLESS OTHERWISE NOTED)
⊕ <td>1</td> <td>OPERATING DEVELOPMENT (UNLESS OTHERWISE NOTED)</td>	1	OPERATING DEVELOPMENT (UNLESS OTHERWISE NOTED)
⊕ <td>1</td> <td>OPERATING DESIGN (UNLESS OTHERWISE NOTED)</td>	1	OPERATING DESIGN (UNLESS OTHERWISE NOTED)
⊕ <td>1</td> <td>OPERATING CONSTRUCTION (UNLESS OTHERWISE NOTED)</td>	1	OPERATING CONSTRUCTION (UNLESS OTHERWISE NOTED)
⊕ <td>1</td> <td>OPERATING INSTALLATION (UNLESS OTHERWISE NOTED)</td>	1	OPERATING INSTALLATION (UNLESS OTHERWISE NOTED)
⊕ <td>1</td> <td>OPERATING OPERATION (UNLESS OTHERWISE NOTED)</td>	1	OPERATING OPERATION (UNLESS OTHERWISE NOTED)
⊕ <td>1</td> <td>OPERATING MAINTENANCE (UNLESS OTHERWISE NOTED)</td>	1	OPERATING MAINTENANCE (UNLESS OTHERWISE NOTED)
⊕ <td>1</td> <td>OPERATING REPAIRS (UNLESS OTHERWISE NOTED)</td>	1	OPERATING REPAIRS (UNLESS OTHERWISE NOTED)
⊕ <td>1</td> <td>OPERATING UPGRADES (UNLESS OTHERWISE NOTED)</td>	1	OPERATING UPGRADES (UNLESS OTHERWISE NOTED)
⊕ <td>1</td> <td>OPERATING MODIFICATIONS (UNLESS OTHERWISE NOTED)</td>	1	OPERATING MODIFICATIONS (UNLESS OTHERWISE NOTED)
⊕ <td>1</td> <td>OPERATING IMPROVEMENTS (UNLESS OTHERWISE NOTED)</td>	1	OPERATING IMPROVEMENTS (UNLESS OTHERWISE NOTED)
⊕ <td>1</td> <td>OPERATING INNOVATIONS (UNLESS OTHERWISE NOTED)</td>	1	OPERATING INNOVATIONS (UNLESS OTHERWISE NOTED)
⊕ <td>1</td> <td>OPERATING RESEARCH (UNLESS OTHERWISE NOTED)</td>	1	OPERATING RESEARCH (UNLESS OTHERWISE NOTED)
⊕ <td>1</td> <td>OPERATING DEVELOPMENT (UNLESS OTHERWISE NOTED)</td>	1	OPERATING DEVELOPMENT (UNLESS OTHERWISE NOTED)
⊕ <td>1</td> <td>OPERATING DESIGN (UNLESS OTHERWISE NOTED)</td>	1	OPERATING DESIGN (UNLESS OTHERWISE NOTED)
⊕ <td>1</td> <td>OPERATING CONSTRUCTION (UNLESS OTHERWISE NOTED)</td>	1	OPERATING CONSTRUCTION (UNLESS OTHERWISE NOTED)
⊕ <td>1</td> <td>OPERATING INSTALLATION (UNLESS OTHERWISE NOTED)</td>	1	OPERATING INSTALLATION (UNLESS OTHERWISE NOTED)
⊕ <td>1</td> <td>OPERATING OPERATION (UNLESS OTHERWISE NOTED)</td>	1	OPERATING OPERATION (UNLESS OTHERWISE NOTED)
⊕ <td>1</td> <td>OPERATING MAINTENANCE (UNLESS OTHERWISE NOTED)</td>	1	OPERATING MAINTENANCE (UNLESS OTHERWISE NOTED)
⊕ <td>1</td> <td>OPERATING REPAIRS (UNLESS OTHERWISE NOTED)</td>	1	OPERATING REPAIRS (UNLESS OTHERWISE NOTED)
⊕ <td>1</td> <td>OPERATING UPGRADES (UNLESS OTHERWISE NOTED)</td>	1	OPERATING UPGRADES (UNLESS OTHERWISE NOTED)
⊕ <td>1</td> <td>OPERATING MODIFICATIONS (UNLESS OTHERWISE NOTED)</td>	1	OPERATING MODIFICATIONS (UNLESS OTHERWISE NOTED)
⊕ <td>1</td> <td>OPERATING IMPROVEMENTS (UNLESS OTHERWISE NOTED)</td>	1	OPERATING IMPROVEMENTS (UNLESS OTHERWISE NOTED)
⊕ <td>1</td> <td>OPERATING INNOVATIONS (UNLESS OTHERWISE NOTED)</td>	1	OPERATING INNOVATIONS (UNLESS OTHERWISE NOTED)
⊕ <td>1</td> <td>OPERATING RESEARCH (UNLESS OTHERWISE NOTED)</td>	1	OPERATING RESEARCH (UNLESS OTHERWISE NOTED)
⊕ <td>1</td> <td>OPERATING DEVELOPMENT (UNLESS OTHERWISE NOTED)</td>	1	OPERATING DEVELOPMENT (UNLESS OTHERWISE NOTED)
⊕ <td>1</td> <td>OPERATING DESIGN (UNLESS OTHERWISE NOTED)</td>	1	OPERATING DESIGN (UNLESS OTHERWISE NOTED)
⊕ <td>1</td> <td>OPERATING CONSTRUCTION (UNLESS OTHERWISE NOTED)</td>	1	OPERATING CONSTRUCTION (UNLESS OTHERWISE NOTED)
⊕ <td>1</td> <td>OPERATING INSTALLATION (UNLESS OTHERWISE NOTED)</td>	1	OPERATING INSTALLATION (UNLESS OTHERWISE NOTED)
⊕ <td>1</td> <td>OPERATING OPERATION (UNLESS OTHERWISE NOTED)</td>	1	OPERATING OPERATION (UNLESS OTHERWISE NOTED)
⊕ <td>1</td> <td>OPERATING MAINTENANCE (UNLESS OTHERWISE NOTED)</td>	1	OPERATING MAINTENANCE (UNLESS OTHERWISE NOTED)
⊕ <td>1</td> <td>OPERATING REPAIRS (UNLESS OTHERWISE NOTED)</td>	1	OPERATING REPAIRS (UNLESS OTHERWISE NOTED)
⊕ <td>1</td> <td>OPERATING UPGRADES (UNLESS OTHERWISE NOTED)</td>	1	OPERATING UPGRADES (UNLESS OTHERWISE NOTED)
⊕ <td>1</td> <td>OPERATING MODIFICATIONS (UNLESS OTHERWISE NOTED)</td>	1	OPERATING MODIFICATIONS (UNLESS OTHERWISE NOTED)
⊕ <td>1</td> <td>OPERATING IMPROVEMENTS (UNLESS OTHERWISE NOTED)</td>	1	OPERATING IMPROVEMENTS (UNLESS OTHERWISE NOTED)
⊕ <td>1</td> <td>OPERATING INNOVATIONS (UNLESS OTHERWISE NOTED)</td>	1	OPERATING INNOVATIONS (UNLESS OTHERWISE NOTED)
⊕ <td>1</td> <td>OPERATING RESEARCH (UNLESS OTHERWISE NOTED)</td>	1	OPERATING RESEARCH (UNLESS OTHERWISE NOTED)
⊕ <td>1</td> <td>OPERATING DEVELOPMENT (UNLESS OTHERWISE NOTED)</td>	1	OPERATING DEVELOPMENT (UNLESS OTHERWISE NOTED)
⊕ <td>1</td> <td>OPERATING DESIGN (UNLESS OTHERWISE NOTED)</td>	1	OPERATING DESIGN (UNLESS OTHERWISE NOTED)
⊕ <td>1</td> <td>OPERATING CONSTRUCTION (UNLESS OTHERWISE NOTED)</td>	1	OPERATING CONSTRUCTION (UNLESS OTHERWISE NOTED)
⊕ <td>1</td> <td>OPERATING INSTALLATION (UNLESS OTHERWISE NOTED)</td>	1	OPERATING INSTALLATION (UNLESS OTHERWISE NOTED)
⊕ <td>1</td> <td>OPERATING OPERATION (UNLESS OTHERWISE NOTED)</td>	1	OPERATING OPERATION (UNLESS OTHERWISE NOTED)
⊕ <td>1</td> <td>OPERATING MAINTENANCE (UNLESS OTHERWISE NOTED)</td>	1	OPERATING MAINTENANCE (UNLESS OTHERWISE NOTED)
⊕ <td>1</td> <td>OPERATING REPAIRS (UNLESS OTHERWISE NOTED)</td>	1	OPERATING REPAIRS (UNLESS OTHERWISE NOTED)
⊕ <td>1</td> <td>OPERATING UPGRADES (UNLESS OTHERWISE NOTED)</td>	1	OPERATING UPGRADES (UNLESS OTHERWISE NOTED)
⊕ <td>1</td> <td>OPERATING MODIFICATIONS (UNLESS OTHERWISE NOTED)</td>	1	OPERATING MODIFICATIONS (UNLESS OTHERWISE NOTED)
⊕ <td>1</td> <td>OPERATING IMPROVEMENTS (UNLESS OTHERWISE NOTED)</td>	1	OPERATING IMPROVEMENTS (UNLESS OTHERWISE NOTED)
⊕ <td>1</td> <td>OPERATING INNOVATIONS (UNLESS OTHERWISE NOTED)</td>	1	OPERATING INNOVATIONS (UNLESS OTHERWISE NOTED)
⊕ <td>1</td> <td>OPERATING RESEARCH (UNLESS OTHERWISE NOTED)</td>	1	OPERATING RESEARCH (UNLESS OTHERWISE NOTED)
⊕ <td>1</td> <td>OPERATING DEVELOPMENT (UNLESS OTHERWISE NOTED)</td>	1	OPERATING DEVELOPMENT (UNLESS OTHERWISE NOTED)
⊕ <td>1</td> <td>OPERATING DESIGN (UNLESS OTHERWISE NOTED)</td>	1	OPERATING DESIGN (UNLESS OTHERWISE NOTED)
⊕ <td>1</td> <td>OPERATING CONSTRUCTION (UNLESS OTHERWISE NOTED)</td>	1	OPERATING CONSTRUCTION (UNLESS OTHERWISE NOTED)
⊕ <td>1</td> <td>OPERATING INSTALLATION (UNLESS OTHERWISE NOTED)</td>	1	OPERATING INSTALLATION (UNLESS OTHERWISE NOTED)
⊕ <td>1</td> <td>OPERATING OPERATION (UNLESS OTHERWISE NOTED)</td>	1	OPERATING OPERATION (UNLESS OTHERWISE NOTED)
⊕ <td>1</td> <td>OPERATING MAINTENANCE (UNLESS OTHERWISE NOTED)</td>	1	OPERATING MAINTENANCE (UNLESS OTHERWISE NOTED)
⊕ <td>1</td> <td>OPERATING REPAIRS (UNLESS OTHERWISE NOTED)</td>	1	OPERATING REPAIRS (UNLESS OTHERWISE NOTED)
⊕ <td>1</td> <td>OPERATING UPGRADES (UNLESS OTHERWISE NOTED)</td>	1	OPERATING UPGRADES (UNLESS OTHERWISE NOTED)
⊕ <td>1</td> <td>OPERATING MODIFICATIONS (UNLESS OTHERWISE NOTED)</td>	1	OPERATING MODIFICATIONS (UNLESS OTHERWISE NOTED)
⊕ <td>1</td> <td>OPERATING IMPROVEMENTS (UNLESS OTHERWISE NOTED)</td>	1	OPERATING IMPROVEMENTS (UNLESS OTHERWISE NOTED)
⊕ <td>1</td> <td>OPERATING INNOVATIONS (UNLESS OTHERWISE NOTED)</td>	1	OPERATING INNOVATIONS (UNLESS OTHERWISE NOTED)
⊕ <td>1</td> <td>OPERATING RESEARCH (UNLESS OTHERWISE NOTED)</td>	1	OPERATING RESEARCH (UNLESS OTHERWISE NOTED)
⊕ <td>1</td> <td>OPERATING DEVELOPMENT (UNLESS OTHERWISE NOTED)</td>	1	OPERATING DEVELOPMENT (UNLESS OTHERWISE NOTED)
⊕ <td>1</td> <td>OPERATING DESIGN (UNLESS OTHERWISE NOTED)</td>	1	OPERATING DESIGN (UNLESS OTHERWISE NOTED)
⊕ <td>1</td> <td>OPERATING CONSTRUCTION (UNLESS OTHERWISE NOTED)</td>	1	OPERATING CONSTRUCTION (UNLESS OTHERWISE NOTED)
⊕ <td>1</td> <td>OPERATING INSTALLATION (UNLESS OTHERWISE NOTED)</td>	1	OPERATING INSTALLATION (UNLESS OTHERWISE NOTED)
⊕ <td>1</td> <td>OPERATING OPERATION (UNLESS OTHERWISE NOTED)</td>	1	OPERATING OPERATION (UNLESS OTHERWISE NOTED)
⊕ <td>1</td> <td>OPERATING MAINTENANCE (UNLESS OTHERWISE NOTED)</td>	1	OPERATING MAINTENANCE (UNLESS OTHERWISE NOTED)
⊕ <td>1</td> <td>OPERATING REPAIRS (UNLESS OTHERWISE NOTED)</td>	1	OPERATING REPAIRS (UNLESS OTHERWISE NOTED)
⊕ <td>1</td> <td>OPERATING UPGRADES (UNLESS OTHERWISE NOTED)</td>	1	OPERATING UPGRADES (UNLESS OTHERWISE NOTED)
⊕ <td>1</td> <td>OPERATING MODIFICATIONS (UNLESS OTHERWISE NOTED)</td>	1	OPERATING MODIFICATIONS (UNLESS OTHERWISE NOTED)
⊕ <td>1</td> <td>OPERATING IMPROVEMENTS (UNLESS OTHERWISE NOTED)</td>	1	OPERATING IMPROVEMENTS (UNLESS OTHERWISE NOTED)
⊕ <td>1</td> <td>OPERATING INNOVATIONS (UNLESS OTHERWISE NOTED)</td>	1	OPERATING INNOVATIONS (UNLESS OTHERWISE NOTED)
⊕ <td>1</td> <td>OPERATING RESEARCH (UNLESS OTHERWISE NOTED)</td>	1	OPERATING RESEARCH (UNLESS OTHERWISE NOTED)
⊕ <td>1</td> <td>OPERATING DEVELOPMENT (UNLESS OTHERWISE NOTED)</td>	1	OPERATING DEVELOPMENT (UNLESS OTHERWISE NOTED)
⊕ <td>1</td> <td>OPERATING DESIGN (UNLESS OTHERWISE NOTED)</td>	1	OPERATING DESIGN (UNLESS OTHERWISE NOTED)
⊕ <td>1</td> <td>OPERATING CONSTRUCTION (UNLESS OTHERWISE NOTED)</td>	1	OPERATING CONSTRUCTION (UNLESS OTHERWISE NOTED)
⊕ <td>1</td> <td>OPERATING INSTALLATION (UNLESS OTHERWISE NOTED)</td>	1	OPERATING INSTALLATION (UNLESS OTHERWISE NOTED)
⊕ <td>1</td> <td>OPERATING OPERATION (UNLESS OTHERWISE NOTED)</td>	1	OPERATING OPERATION (UNLESS OTHERWISE NOTED)
⊕ <td>1</td> <td>OPERATING MAINTENANCE (UNLESS OTHERWISE NOTED)</td>	1	OPERATING MAINTENANCE (UNLESS OTHERWISE NOTED)
⊕ <td>1</td> <td>OPERATING REPAIRS (UNLESS OTHERWISE NOTED)</td>	1	OPERATING REPAIRS (UNLESS OTHERWISE NOTED)
⊕ <td>1</td> <td>OPERATING UPGRADES (UNLESS OTHERWISE NOTED)</td>	1	OPERATING UPGRADES (UNLESS OTHERWISE NOTED)
⊕ <td>1</td> <td>OPERATING MODIFICATIONS (UNLESS OTHERWISE NOTED)</td>	1	OPERATING MODIFICATIONS (UNLESS OTHERWISE NOTED)
⊕ <td>1</td> <td>OPERATING IMPROVEMENTS (UNLESS OTHERWISE NOTED)</td>	1	OPERATING IMPROVEMENTS (UNLESS OTHERWISE NOTED)
⊕ <td>1</td> <td>OPERATING INNOVATIONS (UNLESS OTHERWISE NOTED)</td>	1	OPERATING INNOVATIONS (UNLESS OTHERWISE NOTED)
⊕ <td>1</td> <td>OPERATING RESEARCH (UNLESS OTHERWISE NOTED)</td>	1	OPERATING RESEARCH (UNLESS OTHERWISE NOTED)
⊕ <td>1</td> <td>OPERATING DEVELOPMENT (UNLESS OTHERWISE NOTED)</td>	1	OPERATING DEVELOPMENT (UNLESS OTHERWISE NOTED)
⊕ <td>1</td> <td>OPERATING DESIGN (UNLESS OTHERWISE NOTED)</td>	1	OPERATING DESIGN (UNLESS OTHERWISE NOTED)
⊕ <td>1</td> <td>OPERATING CONSTRUCTION (UNLESS OTHERWISE NOTED)</td>	1	OPERATING CONSTRUCTION (UNLESS OTHERWISE NOTED)
⊕ <td>1</td> <td>OPERATING INSTALLATION (UNLESS OTHERWISE NOTED)</td>	1	OPERATING INSTALLATION (UNLESS OTHERWISE NOTED)
⊕ <td>1</td> <td>OPERATING OPERATION (UNLESS OTHERWISE NOTED)</td>	1	OPERATING OPERATION (UNLESS OTHERWISE NOTED)
⊕ <td>1</td> <td>OPERATING MAINTENANCE (UNLESS OTHERWISE NOTED)</td>	1	OPERATING MAINTENANCE (UNLESS OTHERWISE NOTED)
⊕ <td>1</td> <td>OPERATING REPAIRS (UNLESS OTHERWISE NOTED)</td>	1	OPERATING REPAIRS (UNLESS OTHERWISE NOTED)
⊕ <td>1</td> <td>OPERATING UPGRADES (UNLESS OTHERWISE NOTED)</td>	1	OPERATING UPGRADES (UNLESS OTHERWISE NOTED)
⊕ <td>1</td> <td>OPERATING MODIFICATIONS (UNLESS OTHERWISE NOTED)</td>	1	OPERATING MODIFICATIONS (UNLESS OTHERWISE NOTED)
⊕ <td>1</td> <td>OPERATING IMPROVEMENTS (UNLESS OTHERWISE NOTED)</td>	1	OPERATING IMPROVEMENTS (UNLESS OTHERWISE NOTED)
⊕ <td>1</td> <td>OPERATING INNOVATIONS (UNLESS OTHERWISE NOTED)</td>	1	OPERATING INNOVATIONS (UNLESS OTHERWISE NOTED)
⊕ <td>1</td> <td>OPERATING RESEARCH (UNLESS OTHERWISE NOTED)</td>	1	OPERATING RESEARCH (UNLESS OTHERWISE NOTED)
⊕ <td>1</td> <td>OPERATING DEVELOPMENT (UNLESS OTHERWISE NOTED)</td>	1	OPERATING DEVELOPMENT (UNLESS OTHERWISE NOTED)
⊕ <td>1</td> <td>OPERATING DESIGN (UNLESS OTHERWISE NOTED)</td>	1	OPERATING DESIGN (UNLESS OTHERWISE NOTED)
⊕ <td>1</td> <td>OPERATING CONSTRUCTION (UNLESS OTHERWISE NOTED)</td>	1	OPERATING CONSTRUCTION (UNLESS OTHERWISE NOTED)
⊕ <td>1</td> <td>OPERATING INSTALLATION (UNLESS OTHERWISE NOTED)</td>	1	OPERATING INSTALLATION (UNLESS OTHERWISE NOTED)
⊕ <td>1</td> <td>OPERATING OPERATION (UNLESS OTHERWISE NOTED)</td>	1	OPERATING OPERATION (UNLESS OTHERWISE NOTED)
⊕ <td>1</td> <td>OPERATING MAINTENANCE (UNLESS OTHERWISE NOTED)</td>	1	OPERATING MAINTENANCE (UNLESS OTHERWISE NOTED)
⊕ <td>1</td> <td>OPERATING REPAIRS (UNLESS OTHERWISE NOTED)</td>	1	OPERATING REPAIRS (UNLESS OTHERWISE NOTED)
⊕ <td>1</td> <td>OPERATING UPGRADES (UNLESS OTHERWISE NOTED)</td>	1	OPERATING UPGRADES (UNLESS OTHERWISE NOTED)
⊕ <td>1</td> <td>OPERATING MODIFICATIONS (UNLESS OTHERWISE NOTED)</td>	1	OPERATING MODIFICATIONS (UNLESS OTHERWISE NOTED)
⊕ <td>1</td> <td>OPERATING IMPROVEMENTS (UNLESS OTHERWISE NOTED)</td>	1	OPERATING IMPROVEMENTS (UNLESS OTHERWISE NOTED)
⊕ <td>1</td> <td>OPERATING INNOVATIONS (UNLESS OTHERWISE NOTED)</td>	1	OPERATING INNOVATIONS (UNLESS OTHERWISE NOTED)
⊕ <td>1</td> <td>OPERATING RESEARCH (UNLESS OTHERWISE NOTED)</td>	1	OPERATING RESEARCH (UNLESS OTHERWISE NOTED)
⊕ <td>1</td> <td>OPERATING DEVELOPMENT (UNLESS OTHERWISE NOTED)</td>	1	OPERATING DEVELOPMENT (UNLESS OTHERWISE NOTED)
⊕ <td>1</td> <td>OPERATING DESIGN (UNLESS OTHERWISE NOTED)</td>	1	OPERATING DESIGN (UNLESS OTHERWISE NOTED)
⊕ <td>1</td> <td>OPERATING CONSTRUCTION (UNLESS OTHERWISE NOTED)</td>	1	OPERATING CONSTRUCTION (UNLESS OTHERWISE NOTED)
⊕ <td>1</td> <td>OPERATING INSTALLATION (UNLESS OTHERWISE NOTED)</td>	1	OPERATING INSTALLATION (UNLESS OTHERWISE NOTED)
⊕ <td>1</td> <td>OPERATING OPERATION (UNLESS OTHERWISE NOTED)</td>	1	OPERATING OPERATION (UNLESS OTHERWISE NOTED)
⊕ <td>1</td> <td>OPERATING MAINTENANCE (UNLESS OTHERWISE NOTED)</td>	1	OPERATING MAINTENANCE (UNLESS OTHERWISE NOTED)
⊕ <td>1</td> <td>OPERATING REPAIRS (UNLESS OTHERWISE NOTED)</td>	1	OPERATING REPAIRS (UNLESS OTHERWISE NOTED)
⊕ <td>1</td> <td>OPERATING UPGRADES (UNLESS OTHERWISE NOTED)</td>	1	OPERATING UPGRADES (UNLESS OTHERWISE NOTED)
⊕ <td>1</td> <td>OPERATING MODIFICATIONS (UNLESS OTHERWISE NOTED)</td>	1	OPERATING MODIFICATIONS (UNLESS OTHERWISE NOTED)
⊕ <td>1</td> <td>OPERATING IMPROVEMENTS (UNLESS OTHERWISE NOTED)</td>	1	OPERATING IMPROVEMENTS (UNLESS OTHERWISE NOTED)
⊕ <td>1</td> <td>OPERATING INNOVATIONS (UNLESS OTHERWISE NOTED)</td>	1	OPERATING INNOVATIONS (UNLESS OTHERWISE NOTED)
⊕ <td>1</td> <td>OPERATING RESEARCH (UNLESS OTHERWISE NOTED)</td>	1	OPERATING RESEARCH (UNLESS OTHERWISE NOTED)
⊕ <td>1</td> <td>OPERATING DEVELOPMENT (UNLESS OTHERWISE NOTED)</td>	1	OPERATING DEVELOPMENT (UNLESS OTHERWISE NOTED)
⊕ <td>1</td> <td>OPERATING DESIGN (UNLESS OTHERWISE NOTED)</td>	1	OPERATING DESIGN (UNLESS OTHERWISE NOTED)
⊕ <td>1</td> <td>OPERATING CONSTRUCTION (UNLESS OTHERWISE NOTED)</td>	1	OPERATING CONSTRUCTION (UNLESS OTHERWISE NOTED)
⊕ <td>1</td> <td>OPERATING INSTALLATION (UNLESS OTHERWISE NOTED)</td>	1	OPERATING INSTALLATION (UNLESS OTHERWISE NOTED)
⊕ <td>1</td> <td>OPERATING OPERATION (UNLESS OTHERWISE NOTED)</td>	1	OPERATING OPERATION (UNLESS OTHERWISE NOTED)
⊕ <td>1</td> <td>OPERATING MAINTENANCE (UNLESS OTHERWISE NOTED)</td>	1	OPERATING MAINTENANCE (UNLESS OTHERWISE NOTED)
⊕ <td>1</td> <td>OPERATING REPAIRS (UNLESS OTHERWISE NOTED)</td>	1	OPERATING REPAIRS (UNLESS OTHERWISE NOTED)
⊕ <td>1</td> <td>OPERATING UPGRADES (UNLESS OTHERWISE NOTED)</td>	1	OPERATING UPGRADES (UNLESS OTHERWISE NOTED)
⊕ <td>1</td> <td>OPERATING MODIFICATIONS (UNLESS OTHERWISE NOTED)</td>	1	OPERATING MODIFICATIONS (UNLESS OTHERWISE NOTED)
⊕ <td>1</td> <td>OPERATING IMPROVEMENTS (UNLESS OTHERWISE NOTED)</td>	1	OPERATING IMPROVEMENTS (UNLESS OTHERWISE NOTED)
⊕ <td>1</td> <td>OPERATING INNOVATIONS (UNLESS OTHERWISE NOTED)</td>	1	OPERATING INNOVATIONS (UNLESS OTHERWISE NOTED)
⊕ <td>1</td> <td>OPERATING RESEARCH (UNLESS OTHERWISE NOTED)</td>	1	OPERATING RESEARCH (UNLESS OTHERWISE NOTED)
⊕ <td>1</td> <td>OPERATING DEVELOPMENT (UNLESS OTHERWISE NOTED)</td>	1	OPERATING DEVELOPMENT (UNLESS OTHERWISE NOTED)
⊕ <td>1</td> <td>OPERATING DESIGN (UNLESS OTHERWISE NOTED)</td>	1	OPERATING DESIGN (UNLESS OTHERWISE NOTED)
⊕ <td>1</td> <td>OPERATING CONSTRUCTION (UNLESS OTHERWISE NOTED)</td>	1	OPERATING CONSTRUCTION (UNLESS OTHERWISE NOTED)
⊕ <td>1</td> <td>OPERATING INSTALLATION (UNLESS OTHERWISE NOTED)</td>	1	OPERATING INSTALLATION (UNLESS OTHERWISE NOTED)
⊕ <td>1</td> <td>OPERATING OPERATION (UNLESS OTHERWISE NOTED)</td>	1	OPERATING OPERATION (UNLESS OTHERWISE NOTED)